

Impact

Kansas State University College of Engineering

Fall 2000

"The WISE program showed me a completely different side to engineering," said Justin Hendrix, senior in mechanical engineering from Hutchinson. "There's a big difference between determining a solution to a problem and actually being able to implement it into society."

"I did not find the type of engineering you would find in a book," agreed Lindsay Bose, senior in architectural engineering from Gretna, Neb., "but rather the type that can only be attained through first-hand experiences and the shared wisdom of others."

Justin Hendrix
and Lindsay Bose

A "capital" experience

Both were commenting on their summer internship experiences as a part of the WISE program—Washington Internship for Students in Engineering. Each spent 10 weeks in the nation's capital—May 27 through Aug. 7—learning how government officials make decisions on complex technological issues, and how engineers contribute to legislative and regulatory public policy issues. Both were given the opportunity to interact with congressional leaders, federal administration, and the engineering industry, as well as being required to research and complete a paper on current engineering public policy.

WISE interns from around the country were housed on the same floor of a George Washington University dorm in the "heart of D.C."—close to the popular areas of the Mall, White House, DuPont Circle, and Georgetown.

Hendrix was sponsored by the American Nuclear Society and conducted his research on the different political issues involved with the Yucca Mountain spent-nuclear fuel repository, west of Las Vegas. His office was located at the Nuclear Energy Institute, a lobbyist organization connecting all nuclear utility companies.

"I had a really nice office," he said, "with a lot of people very educated about my research topic available to help me out."

The National Society of Professional Engineers sponsored Bose, with her topic of concern being the re-evaluation of brownfields programs based on a comparison to military base realignment and closure programs.

"Our offices were in walking distance of the dorm," Bose said, "and the sponsoring societies provided mentors who would point out key issues and offer valuable contacts."

With no set work schedule, there were no "typical" days for the interns—some would involve four or more separate meetings with groups or individuals, while others were spent totally on research or sight-seeing.

"People know what the WISE program is," said Bose, "and how valuable it is for creating future interest in engineering and politics; therefore, the quality and quantity of people wanting to meet us was overwhelming."

Bose had dinner with EPA Administrator Carol Browner, ran into *The Price Is Right* television host Bob Barker while entering the House office building one day, and mentioned seeing the Dali Lama at a cultural festival held on the Mall.

Hendrix described one of his more memorable experiences as being invited to the Pentagon to talk with Gen. Richard Myers, Vice Chairman Joint Chiefs of Staff and

KSU College of Engineering alumnus.

"We were able to sit in his office and talk about Washington, D.C., the military, and K-State football for quite awhile," Hendrix said. "After that he introduced me to others who worked on the Joint Staff and who took me around the building and told me about a lot of things that take place there."

Bose commented on the presence of "many K-Staters" in attendance at a WISE reunion held this summer in conjunction with her and Hendrix' internships. This should come as no surprise as in the past 16 years, K-State engineering has had more students—29—selected to participate in the WISE program than any of the other 300 engineering schools in the nation.

"Many WISE interns catch the D.C. 'bug' and return to the city after graduation," Bose said. "Many are interested not just in engineering but in law, politics, and Ph.D. research. The experience was really eye opening for me. I now look at what I can accomplish nationally instead of just in the Midwest or even at K-State."

Hendrix concurred, stating, "The program has changed my outlook on politics. I realize the importance engineers have in making educated decisions concerning public policy. I plan on working my way back toward Washington, D.C., and becoming involved in our federal government."

—by Mary Rankin

Message from the Dean



The challenge of providing a dynamic and effective engineering education is a never-ending cycle where we must focus on the future, while building on a foundation of the past and present.

Our September dedication of Fiedler Hall was very much a picture of this challenge. Alumni, friends, faculty, staff, and students gathered in the atrium of Rathbone Hall, awaiting the ribbon cutting for the "official" entry to Fiedler—the past, present, and future embodied in this one event.

As we face the rapidly changing educational content of our profession, it must be our focus to best funnel and organize these changes for our students within the traditions of an engineering curriculum.

Recent gifts to our college from Alice Fiedler, in memory of her husband, George, and his commitment to engineering education and his professional successes, represent her understanding of this cycle. Fiedler Hall, the building, represents the foundation of engineering education. And as Alice said, it will stand "for hundreds of years" and will allow "thousands of students to reach their goals."

But as expressed in additional comments at the dedication, Alice is also aware of present needs and future challenges. "In my trust," she explained, "I have provided a substantial major endowment to Kansas State University to cover the needs of Fiedler Hall and Fiedler Engineering Library in perpetuity. So, as the years go by, and the world changes and opportunities arise to make the world a better

place, Kansas State University will be in a position to lead the way and stay on top."

Mary and Raymond Malone understand that a part of this future is looking towards increased diversity to fill the demand for the next generation of engineers and computer scientists. Our new Eyestone Distinguished Lecture Series will bring entrepreneurs and innovators in our profession to campus to demonstrate how a traditional engineering education offers the foundation to lead the way in the 21st century.

Building on our past foundation, with present-day success and the promise of future greatness, sustains and strengthens our Seaton Society membership. We strive to be worthy of this group's outstanding support by providing an institution in which they can take great pride. Our students are key to this effort as they make the most of their educational opportunities, going head-to-head with the top engineering programs in the country and winning prestigious internships, scholarships, chapter awards, and team competitions.

Continuing on this educational quest of blending the past, present, and future, can only bring us ever closer to realizing our vision: "The Kansas State University College of Engineering will be the best comprehensive engineering college in the United States."

T S King
Terry S. King, Dean

Student chapters

named best in country



Entrants for Mini Baja West gather on the lawn of the Engineering Complex in April. K-State's student chapter of SAE hosted the event for the second year in a row and has been chosen to host again in 2001.

SAE

The Society of Automotive Engineers has named the Kansas State University College of Engineering Society of Automotive Engineers student chapter as its recipient of the Honeywell Outstanding SAE Collegiate Branch Award. This annual recognition is given to a student chapter with exemplary performance in the areas of technical meetings, projects, membership continuity, and recruitment.

"Our Society of Automotive Engineers student chapter has been very active in providing K-State students the opportunity to put their classroom learning into practice," said David Pacey, associate professor in mechanical and nuclear engineering and advisor to the group. He had received the Society of Automotive Engineers Faculty Advisor Award earlier this year.

"David Pacey and our Society of Automotive Engineers student chapter continue to bring great distinction to the College of Engineering," Terry King, dean of the college, said. "To have been recognized by SAE with both the Faculty Advisor and Outstanding Collegiate Branch awards in the same year is a proud accomplishment for the college."

AGC

Fulfilling the chapter's motto, "Skill, Integrity, Responsibility," Kansas State University's student chapter of Associated General Contractors was selected to receive the 1999-2000 Outstanding Student Chapter Award. It was presented at the Associated General Contractors of America 2000 midyear meeting in Philadelphia in September.

"The chapter's activities category emphasizes dedication to the group's motto and also seeks a strong working relationship between the local sponsoring chapter and the student chapter. K-State's student chapter is sponsored by the Associated General Contractors of Kansas Inc., Topeka.

"The department has much to be proud of," said David Fritchen, department head of architectural engineering and construction science. "This award gives a lot of credit to the leadership our students possess."

The construction science and management program was praised for having one of the most outstanding construction education programs in the country, having received the first place award more than any other school in the nation, said James Goddard, chapter

advisor and professor in architectural engineering and construction science. "We have a history of winning," he said. "Since the 1970s, we've won first, second, or third in this competition more than any other school in the country."

ASAE

The Kansas State University Department of Biological and Agricultural Engineering's student branch of the American Society of Agricultural Engineers has been selected as the most outstanding ASAE Student Branch for the larger branches, based on their initiative and accomplishments for the past year. The group was honored at ASAE's annual international meeting in Milwaukee in July.

The American Society of Agricultural Engineers is the society for engineering in food, agricultural, and biological systems. Founded in 1907, it has more than 9,000 professional and technical organization members worldwide.

"Because of our win in the larger branch competition, we are surely the most outstanding ASAE student branch in North America for 2000," said James Koelliker, biological and agricultural engineering department head.

"The chapter owes a big thanks to Stefanie Shoup and Dawn Dechand, scribes for the student branch. They prepared the report for the judging of this competition," said Kyle Mankin, assistant professor in biological and agricultural engineering and faculty advisor for the student branch.

AIChE

For the sixth consecutive year, the K-State Student Chapter of the American Institute of Chemical Engineers has been named a national Outstanding Student Chapter for 1999-00.

While up to 15 outstanding chapter awards can be given each year, only nine chapters of the 150 nationwide were deemed worthy of the national award this year. This places K-State's chapter in the top six percent in the country. It has remained in the top 10 percent of chapters nationwide for the last six years.

"It is an accomplishment that does much for department prestige nationally and clearly demonstrates the quality, enthusiasm, and dedication of our students," said Stevin Gehrke, department head of chemical engineering.

Chapter advisor is Walter Walawender, professor of chemical engineering. Qualifications for the award include number of members in the organization, level of student chapter participation, and plans and activities carried out by the various committees.

Research – the “capstone” of Engineering Honors

“We feel the honors program of the College of Engineering is a strong recruiting tool—another incentive to come to K-State,” said Richard Gallagher, associate dean for academics and administration and college honors program director. “It gives students the ability to structure an academic program that is adaptable to what they want to do in the future.”

Entering freshmen engineering students with a minimum 29 ACT composite score, or a ranking in the top five percent of their high school graduating class, automatically qualify for the College of Engineering Honors Program. To remain in the program, those students must maintain a GPA of 3.50. The “honors” designation allows them major input in custom designing their curricula and the opportunity to earn undergraduate credit hours for research projects.

At the same time, a transfer student with a cumulative GPA of 3.50 or greater in at least 12 semester hours and a student with a KSU cumulative GPA of 3.50 or greater in at least 12 semester hours, is also eligible for the program.

“Ultimately, the honors program is open to all top GPA students in the college,” explained Gallagher. “If a student works hard enough, he or she is eligible.”

The basic thrust of the honors program, Gallagher said, is taking three, one-hour seminar classes during the freshman and sophomore years, and then earning two to four hours of credit working on a research project a student’s junior and senior years.

“The capstone of the engineering honors program is undergraduate research,” according to Dick Hayter, associate dean for external affairs and honors seminar professor. Students are able to work one-on-one with a faculty mentor on a research project, and often times this leads to recognition through scholarly publications, as well as state and national exposure through presentations at conferences and professional meetings.

“In getting to ‘rub elbows’ with faculty members in the research lab,” Gallagher said, “honors students are offered stimulating and intellectual challenges consistent with their abilities and interests.”

Christopher Whitmer, senior honors student in mechanical engineering, said his research experience in

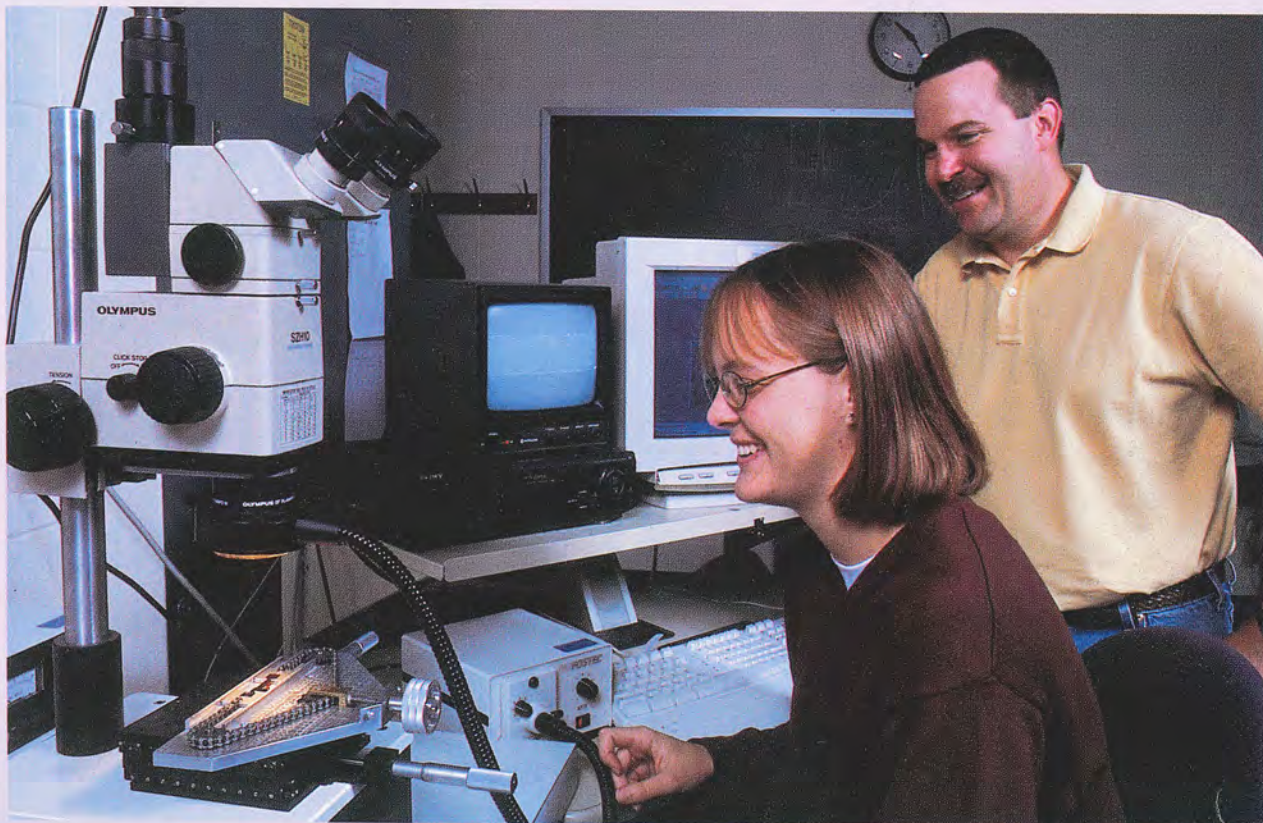

Kevin Lease, standing, associate professor of mechanical and nuclear engineering, assists Megan Shumaker, seated, senior in mechanical engineering, with her honors research project.

control of acoustical noise with Atul Kelkar, associate professor in mechanical and nuclear engineering, exposed him to many facets of control theory.

“The experience has given me a taste of what it’s like to do ‘real’ research,” he said, “while improving my contact with faculty and working in a field where I hope to do my graduate study.”

Megan Shumaker, also a senior in mechanical engineering, will soon be starting her research project work with Kevin Lease, associate professor of mechanical and nuclear engineering, testing a new surface treatment for fibers in composite materials.

While Shumaker is confident the research experience

will be valuable, she noted how the honors seminar courses helped frame her curriculum choices.

“Each week someone from one of the engineering departments would come and talk about what was involved in a particular major,” she said. “At the time, I was struggling to choose a major and didn’t really know what they were all about. This experience gave me an understanding of the various disciplines and helped me decide which was best for me. I really enjoyed those lectures and the guest speakers from industry.”

—by Mary Rankin

New solar car in design stage

With Apollo winding up the year in style, finishing second in this past summer’s Formula Sun Grand Prix, members of the K-State engineering solar car team are hard at work on the next car, which will compete in races in 2001.

Access to a new software program, ProEngineer, has made the design task much easier this time around, according to project manager, Scott Hammack, senior in mechanical engineering.

“Use of ProEngineer has eliminated the need for building prototypes and has allowed us to computer-model the aerodynamics of our designs,” Hammack said. “We started with six completely new concepts and designs, narrowed it to two, and now have our final choice.”

Mechanical construction on the new car is set to begin in December. Along with improved aerodynamics and a narrower wheelbase than Apollo, the 2001 model will also sport an entirely new battery system.

Apollo used nine, 12-volt lead-acid car batteries, Hammack explained, adding 300 pounds of weight to the car. This time 650, 3.7-volt lithium-ion batteries, storing the same amount of energy, but weighing 220 pounds less, will power the car.

Wanted: Donation of a 3/4 or 1-ton pickup, big block or diesel engine, to pull trailer and solar car. Contact Prof. Norman Dillman, 785-532-4646, dillman@eece.ksu.edu

“One of our sponsors, Dallas Semiconductor, flew our team members to their plant in Dallas so we could work with them on the battery-design elements,” Hammack said. “They then donated the chips, called battery-charge controllers, that make the whole system work.”

The 40+ students currently involved in the project, and team advisor Norman Dillman, professor of electrical engineering, have high hopes for this year’s car. The first race is scheduled in May at the recently completed Kansas Speedway in Kansas City, Kan. This will be a qualifying round for the American Solar Challenge, set for July, where entrants will race from Chicago to Los Angeles. Also on the slate is the World Solar Challenge in November 2001 where cars will race across Australia from north to south.

Follow the progress of the solar car project by visiting the team’s Web site at www.engg.ksu.edu/solarcar.

—by Mary Rankin

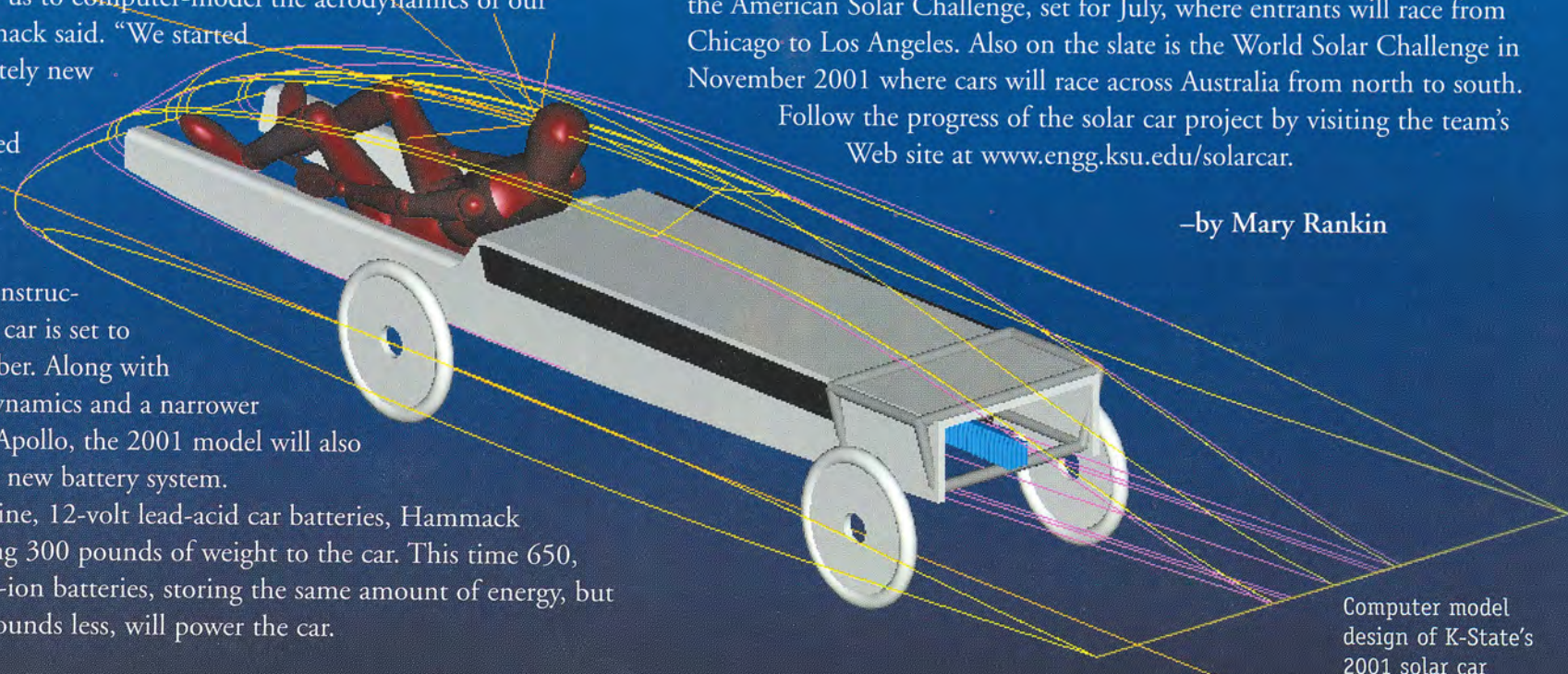

Computer model design of K-State’s 2001 solar car

A day of excitement & dedication

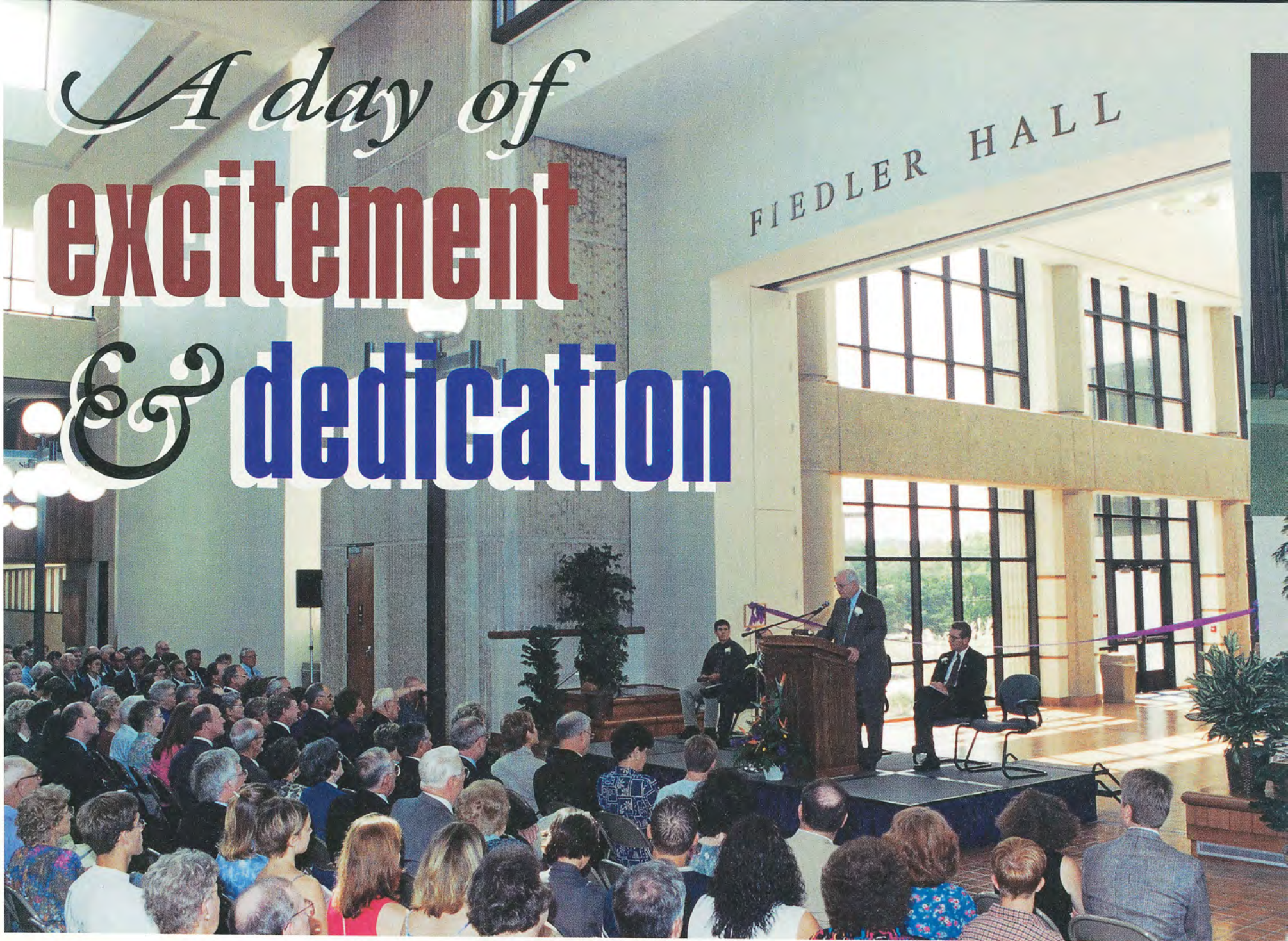

A dedication, a dinner, a dance—and yet so much more. Words used to describe events of Sept. 9 included “exciting,” “historic,” “awesome,” “progressive.” More than 250 guests, dignitaries, faculty, staff, and students assembled for the official dedication of Fiedler Hall—a 75,000-square-foot addition to the Engineering Complex. Attendees of the Seaton Society Banquet honored the Class of 2000 Hall of Fame inductees, as well as the inaugural group of Professional Progress awardees. And the Engineering Ball, sponsored by the Engineering Student Council, capped off the festive day, as strains of live band music played on into the night.



Clockwise from above: A large crowd gathers for the Fiedler Hall dedication; Engineering Student Council President Cory Lafferty presents purple roses to Alice Fiedler; KSU President Jon Wefald, right, and Dean Terry King assist Alice Fiedler with ribbon cutting.



Above: Guests tour Fiedler Library; **right:** Alice Fiedler and Herb Whitney, CE '63, take to the dance floor; **far right:** alumni, guests, and students enjoy the music and magic of the first annual Engineering Ball.

Engineering complex rocks



Professional Progress Awards

A new, annual recognition was begun at this year's Seaton Society Banquet—the Professional Progress Award. Each department head could nominate one person who had received his or her last degree from Kansas State within the past 20 years. This individual must have demonstrated significant success in one or more of the following areas: professional accomplishment, service to society and/or profession of engineering, support of K-State engineering, and other distinguished activities. He or she must also show promise of continued success. The 2000 awardees are, back row from left, Bill Cary, CS '87; Sue Barsamian, EE '81; Jerry Marr, AE '83, MS '84; and Ronald Brown, ARE '76; front row from left, Jacquelyn Zidek, ISME '86; Kevin Honomichl, CE '86; and Scott Love, ChE '80.



Above: Seaton Society Banquet guests give their attention to the podium.

Hall of Fame

The Kansas State University College of Engineering Hall of Fame—the recognition of successful alumni who have reached the highest levels of achievement in their professional endeavors and who are committed to maintaining the highest standards of their profession—this year saw five new members inducted into its numbers, three comprising the Class of 2000, and one each from the previous classes of 1998 and 1999. The honorees, above, from left are Arnold Allemang, '00; Kuo-Ming Wang, '99; Robert Smith, '00; Robert Thorn, '98; and Robert Snell, '00.

Scholarship achievement record continues to shine



Briggeman

Udall Scholarship
\$5,000
Steven Briggeman
senior
Agricultural
Technology
Management



Dechand

Udall Scholarship
\$5,000
Dawn Dechand
senior
Biological and
Agricultural
Engineering



Emerson

**Lighting Design
Alliance Scholarship**
\$2,000
Emily Emerson
senior
Architectural
Engineering

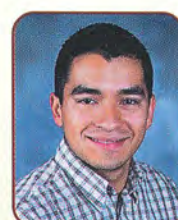

Close

**Gates Millennium
Scholarship**
\$2,800
Larry Close
junior
Civil Engineering



Byer

**Wayne Kay
Scholarship**
\$2,500
Eric Byer
senior
Manufacturing Systems
Engineering

Alumni News

1950

Ray Thompson (EE) was honored by the Science Academy of Austin at LBJ High School May 5, 2000. For his commitment and enthusiasm, the magnet program of the Austin Independent School District dedicated their Science Academy banquet to Thompson.

1958

Francis Grillot, Jr. (ChE) retired from his position as national sales manager for domestic industrial products for Temcor on March 31, 2000. He retired from his position as vice president of international marketing for A.O. Smith Engineered Storage on June 1, 1997. He currently resides in Fairfield Bay, Ark. fgrillot1@aol.com

1962

John E. Miller (BAE) retired as a pilot for Delta Airlines in 1999. 529 Boy Scout Rd., Newman, GA 30263.

1967

Gary D. Boyer (NE) retired in January 2000 after 33 years in the nuclear energy business. The last 13 years of his career were spent at the Wolf Creek Nuclear Operating Corporation where he served in several management and executive positions.

1972

Warren Feerer (IE) began a new position in February 2000 as director of operations, East Coast, for DFG Foods, a division of Foodbrands America.

1975

G.P. "Bud" Peterson (ME, M.S., '80) was named provost of Rensselaer Polytechnic Institute. Peterson has served as head of the mechanical engineering department, assistant director of the Texas Engineering Experiment Station, associate

dean of engineering and associate vice chancellor for the A&M system. As provost at Rensselaer, he will report to the president and serve as a member of the president's cabinet.

1986

Mark Verschelden (IE, M.S., '87) and **Katherine Achuke-Verschelden (IE '87)** announce the birth of their daughter, Sarah Marie, on Oct. 1, 2000. Sarah joins brothers Thomas, 7, and Samuel, 2, in Shawnee, Kan.

1987

Chris Stingo (ME) and his wife, Kelly, announce the birth of their daughter Olivia on April 27, 2000. Olivia joins sisters Alexandra and Audrey. Chris is the branch manager for Johnson Controls in Wichita, Kan. chris.stingo@jci.com

1988

Brenda J. Bitter (CE) announces the birth of a son, Christopher Nicholas, on May 6, 2000. 1910 Highway 18, Plainville, KS 67663.

1989

Michael Funk (ME) and his wife, Jennifer, announce the birth of their second child, Megan Elizabeth, on March 26, 2000. Michael is the plant engineer at Atchison Casting Corp. in Atchison, Kan.

Claudia (Cecilia) Maldonado Hall (IE) wed John Hall in 1992. They have three children: Kiersten, 9; Max, 5; and Isabel, 3. Claudia is currently working at National Instruments in Austin, Texas, as an industrial engineer in the process improvement group.

1990

Johnnie Jarred (ME) joined C2 Technologies as manager of operations for the company's subsidiary, C2 Technical

Services, L.L.C., which provides gas measurement and communication services for the energy industry. The company is based in Tulsa, Okla.

1992

Steven Hilger (ME) accepted a position with Calpine Corporation Construction Management Group as the assistant project engineer at the Aries Power Plant in Pleasant Hill, Mo. Steven also announces the birth of his son, Jacob Andrew Hatteberg Hilger, on Oct. 1, 1999.

1994

Prashant Gandhi (ChE) received his master's in business administration from the Graduate School of Business at the University of Chicago in June 2000. He has accepted a job as an associate at McKinsey & Company in Dallas, Texas. mpgandhi@gsb.uchicago.edu.

1996

Doug Wachsicht (CS) is currently working as a project manager for Goodwin Bros. Construction Co. in Crystal City, Mo.

Daniel Knox (IE) married Vickie (Clements) Knox of Roeland Park, Kan., Aug. 28, 1999. Daniel is a technical resource manager for Frito Lay in Irving, Texas. Vickie is a counselor at Consumer Credit Counseling Services. They are both active in the teen youth group at their church and are enjoying life in the Dallas-Fort Worth metroplex. They don't have any children yet, but adopt dogs from their apartment complex.

1999

Wendy Krotz (ARE) wed Jeff Macoubrie June 24, 2000. Wendy is currently employed at Henderson Engineers in Kansas City.

Deaths

1936

Howard Lee Hartman (ChE) died Aug. 5, 1999, in Lansing, Mich., at the age of 85. Hartman retired from C.W. Marsh Company in Muskegon, Mich., after 41 years of service. He is survived by two daughters.

1939

Frank A. Cowell (EE) died July 7, 2000, at the age of 85. He was employed by Phillips Petroleum Co. from 1939 until 1980. He is survived by his daughter, Karen. He was preceded in death by his wife Ellen.

1944

Gordan Morris Fitch (ME) died April 19, 2000, in Dallas, Texas. He served with NACA (NASA) during World War II. Fitch was employed in aircraft engineering with Vought Aircraft for 27 years and 10 years with General Dynamics. He is survived by his wife, Mary Ann, one son, two daughters, and five grandchildren.

1947

Charles W. Olson (ChE) died May 25, 2000, in Orlando, Fla., from prolonged heart disease. He is survived by his wife, Joan (Penny); three children, Vernon, Zoe Ann, and Ben and seven grandchildren.

1950

Harold L. Erskine (M.S., ChE) died Feb. 14, 2000. Harold worked for Sun Oil, Inc. until his retirement in 1982. He was involved with the Suncor oil sands project in Alberta, Canada, during many of those years. His first wife, Edra Lowe, precedes him in death. He is survived by wife, Eleanor, two stepdaughters, and three grandchildren.

1951

Robert N. Herwig (EE) died July 5, 1999, in Tulsa, Okla., following complications from Lou Gehrig's Disease. The 71-year-old was a retired Tulsa realtor and aerospace engineer. He is survived by wife, Carol; son, Craig; and daughters Kim and Linda. 7021 E. 53rd St., Tulsa, OK 74145.1955

1955

Gilbert Johnson (CE) died Aug. 18, 2000. Johnson founded G.E. Johnson Construction in 1967. His company helped build structures such as the Colorado Springs World Arena, parts of the U.S. Olympic Training Center, the Pikes Peak Center, Broadmoor West and the entire downtown Plaza of the Rockies complex. Johnson is survived by wife, Barbara, two daughters, two stepdaughters, two sons, and one stepson.

College Faculty Award Winners



Presidential Award for Outstanding Department Head
Dr. Virgil Wallentine, Computing and Information Sciences

Wallentine

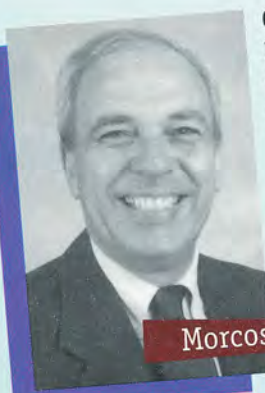

Commerce Bank Undergraduate Outstanding Teaching Award
Dr. Medhat Morcos, Electrical and Computer Engineering

Morcos



Outstanding Undergraduate Advisor Award
Professor Ray Hightower, Assistant Dean for Student Services

Hightower



Myers-Alford Memorial Teaching Award
Dr. Mark Schrock, Biological and Agricultural Engineering

Schrock



James L. Hollis Memorial Award for Excellence in Undergraduate Teaching
Dr. Ronaldo Maghirang, Biological and Agricultural Engineering

Maghirang



Bob and Lila Snell Distinguished Career Award for Excellence in Undergraduate Teaching
Dr. Donald Hummels, Electrical and Computer Engineering

Hummels



Engineering Research Excellence Award
Dr. Matthew Dwyer, Computing and Information Sciences

Dwyer



A look back . . .

While unable to identify anyone pictured, Phil Kirmser, retired electrical engineering professor; Dick Akin, chemical engineering professor; and Dean Eckhoff, professor of mechanical and nuclear engineering, were able to help establish the following "facts" for this issue's historic photo: location—the engineering machine shops, located in what is now known as Seaton Court; time period—late 1930s to early 1940s (based on clothing styles and the year of the barely visible automobile outside the window on the left); activity going on—a project likely involved with grinding and/or welding (note the grinder under the window on the left, and the acetylene torch, lower right). Any readers who can add information, please contact us at our *Impact* news address (see "Keep Connected" at right).

A belief in rewarding effort

continued from cover

their qualifications and substance of response were clearly outstanding."

In 2000, the Malones added a fourth \$2,000 scholarship to the association's annual scholarship total, "to encourage other member companies to do the same," Malone said. Three of the four recipients were once again K-State engineering students, the fourth attending the University of Missouri-Columbia.

Also in 2000 came the Malones' decision to establish the Malco Multicultural Scholarship, which will provide annual financial assistance to a student enrolled in the K-State Multicultural Engineering Program.

"I believe affirmative action will soon be a thing of the past," Malone said, "and as entrepreneurs and good citizens, my husband and I believe we should give back to the industry and community we've benefited from.

"You also want to give back to someone who's really trying," she continued. "And we knew from meeting with Thirkelle Howard, director of the Multicultural

Engineering Program at Kansas State, that very often minority students must work more hours while in school to finance their educations, leaving less time for study. We want to be able to encourage these students to concentrate on their studies with this scholarship."

Mary Malone serves on the Multicultural Engineering Program Advisory Council of the College of Engineering and has been instrumental in distributing résumés of K-State minority engineering students to major construction companies in the Kansas City area to help with internship and employment opportunities.

"We are so grateful for the tremendous support of Mary and Raymond Malone of Malco Steel, Inc.," Howard said. "Their

contributions of time and finances have had a positive impact on both the multicultural program and the College of Engineering."

"While certainly appreciative of their strong financial support, the college cannot overlook how our students will also benefit from the Malones' example of a successful entrepreneurship," said Terry King, dean of the College of Engineering. Founded as a home-based business in 1984 with \$200 cash and \$1,800 worth of used construction equipment, in 1988 Malco Steel, Inc., was listed seventh on Dun and Bradstreet and was named one of "Entrepreneur's Top-10 Minority-Owned Small Businesses in the United States."

—by Mary Rankin

Sacco: "Living and Working in Space"

"Living and Working in Space—A Scientist's/Teacher's Perspective" was the title of the inaugural address of the Eystone Distinguished Lecture Series, presented by Dr. Albert Sacco, Jr., Nov. 30 in Fiedler Auditorium.

Sacco holds the George A. Snell Chair of Engineering and is director for the Center for Advanced Microgravity Materials Processing at Northeastern University in Boston. He flew as a payload specialist on a 16-day mission aboard the space shuttle Columbia in 1995.

Support for the Eystone Distinguished Lecture Series is provided by an endowment to the College of Engineering from the late Fred and Mona Eystone. Fred graduated from K-State in 1941 with a bachelor's degree in electrical engineering. He was a member of the College of Engineering Advisory Council and received the Distinguished Service Award in 1961.

"This endowment has allowed us to develop a lecture series that will focus on creativity and entrepreneurship in the areas of engineering and applied sciences," said Terry King, dean of the College of Engineering. "We want to bring speakers of Dr. Sacco's caliber to campus so that our students will be aware of the challenges and rewards available to those contributing their capacities and talents toward innovation."



Dr. Al Sacco, Jr., payload specialist on a 16-day mission aboard the spacecraft Columbia.

Impact

IMPACT is published twice a year by the Kansas State University College of Engineering, Manhattan, KS 66506-2588. It is available on the World Wide Web at <http://www.engg.ksu.edu>.

Issue No. 4 Fall 2000

Editor

Mary Rankin

Contributing writer

Jennifer Ryan

Art director

Rich Gardner

Graphic designers

Christina Ghere, Bob Davis

Photographers

Dan Donnert, John LaBarge, Al Rankin

Keep Connected

Take a few minutes to jot down job changes, births, deaths, professional or other activities, your retirement, or remembrances you'd like to share. Send your news to *Impact* by mail, e-mail or fax, listed below.

Want your classmates to contact you? Check the appropriate box below and we will include your address with your news. You must indicate that you want this information printed.

Please select and list only one type of contact information for publication.

Mail Phone E-mail

Name

Major/Class year

Address

Phone

E-mail address

News for *Impact*

Send to:

IMPACT Editor
Engineering Communications
Kansas State University
133 Ward Hall
Manhattan, KS 66506-2508
or e-mail: impact@engg.ksu.edu
or FAX: 785-532-6952

Job market looks good for engineering grads

Cited as the largest and "most successful to date" by coordinator Barbara Finnegan, the 17th annual College of Engineering Career Fair/Recognition Banquet, hosted by 54 companies and sponsors, was attended by over 500 students, faculty, and employer representatives.

More than 120 students were recognized for their successes in 1999-2000 in the categories of individual student awards and scholarships, chapter and honor society awards, teams competition and awards, and study abroad.

The banquet, held Sept. 18 in the Manhattan Holiday, gave potential employers an opportunity to host a table of six to eight students, allowing representatives to answer any questions about their orga-



Left: Company recruiters answer questions and promote employment opportunities in the Rathbone Hall atrium.

Above: K-State engineering students mingle with employer representatives and sponsors prior to the 17th annual College of Engineering Career Fair/Recognition Banquet. **Below left:** Students pick up name tags and host-table information before the evening's festivities begin.



nizations and to become better acquainted with the K-Staters.

"The market for graduating engineers is unbelievable this year," said Marcia Schuley, associate director of K-State Career and Employment Services.

"Many of our May graduates are already accepting positions," Schuley listed several companies involved in recruitment efforts this fall in addition to attending the all-university career fair Sept. 19, among those being Dow, Sprint, National Instruments, and Motorola.

Michael Zeller, applications engineer with National Instruments, Austin, Texas, was part of a five-member traveling team on a two-week recruiting mission to seven

key area engineering schools—Kansas State, Oklahoma State, Iowa State, and Texas Tech Universities; and the Universities of Illinois, Wisconsin, and Michigan.

"K-State is one of our schools where we're ramping up our presence," he said. "We've only recruited here for three semesters, but we came back to where we get good people."

"It's exciting to see our students sought after in this way," said Dean of the College of Engineering Terry King. "These recruiting efforts, while certainly a reflection of a strong economy, are nonetheless a positive validation of our efforts to prepare our students for promising careers in engineering and computer science."

Non-Profit Organization
U.S. Postage Paid
Permit #525
Manhattan, KS 66502

KSTATE
Kansas State University

College of Engineering
Kansas State University
146 Rathbone Hall
Manhattan, KS 66506-5201
401

Dinner is served ...



Highlights of Fiedler dedication, Section Society Banquet, and Engineering Ball. See inside.

A belief in rewarding effort

Neither Mary Malone nor her husband, Raymond, founders of Malco Steel, Inc., are Kansas State University alumni; nor are any of their five children. Malco Steel employs no K-State graduates. So why would one of Kansas City's most visible and successful African-American-owned construction firms choose the K-State College of Engineering as the site to endow the Malco Multicultural Scholarship?

"K-State students just outshine everybody else," said Mary Malone, in explaining the answer to that question. She was first "introduced" to K-Staters while serving in the capacity of scholarship committee chairperson for the Minority Contractors Association of Greater Kansas City. In 1999, the group decided to offer three, \$2,000 scholarships a year to minority students from the area. Fifty applications were distributed to eight area colleges and universities. All three scholarships were awarded to K-State engineering students.

"More students from Kansas State returned the applications than from anywhere else," Malone said, "and

continued on page 7

Important

Mary Malone, Malco Steel, Inc., left, and Katrina Lindsey, junior in mechanical engineering, Minority Contractor's Assoc. Scholarship recipient



KSTATE
ENGINEERING